

Laser-Alignment System ECO-PSD



Characteristics:

- Resolution approx. 10µm
- Sensor-centricity <15µm
- Measurement range +/- 1.5 mm
- Sensor with daylight filter
- Sensor with radial and axial connector
- High-contrast display with 14mm digit-size
- Battery powered and Power "ON" LED
- Usable range up to 15m
- Mobile, sturdy design
- Customisation of the mechanical system interface possible to meet user requirement

Short description

The laser alignment system **ECO-PSD** is a cost effective system to align centres of machinery or parts thereof. This system offers an attractive alternate for measuring processes which do not require the operator comfort and protocol features of a higher level system such as the ILEE PSD-10.

The laser alignment system consists of an axially centre adjustable laser source, a centred Sensor unit and a large display unit. The sensor connects by wire to the display unit. On the sensor housing 2 plugs are available (see picture above) which permit either axial or radial cable connection. The cable length can be defined to match your need. If required, several cables can be connected in series to extend the total length.

The adjustment of the laser beam on the 2-dimensional sensor surface produces an electrical signal corresponding to the laser position on the sensor. This enables the identification of a deviation from the centre. When the laser is positioned to the sensor's centre the value in the display is „0.00“ (picture 1).

Display of laser position in relation to the sensor's centre.

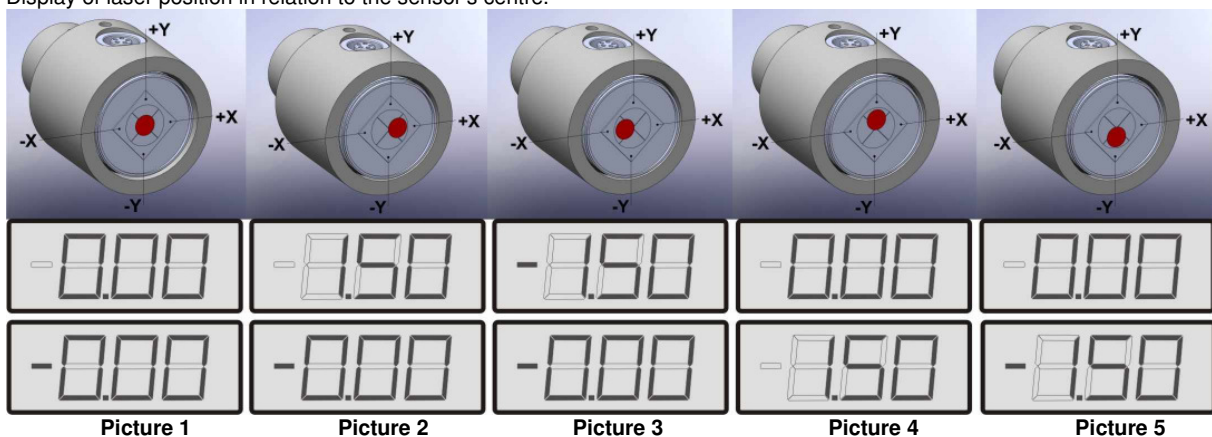

The upper display shows the deviation on the X-axis whereas the prefix identifies the direction (Picture 2). The value „1.50“ shows a deviation of approx. 1.5mm of the laser from the centre to the right and the value „-1.50“ shows a deviation of the laser from the centre to the left (Picture 3).

The lower display shows the deviation on the Y-axis and, whereas the prefix identifies the direction (Picture 4). The value „1.50“ shows a deviation of approx. 1.5mm of the laser above the centre and the value „-1.50“ shows a deviation of the laser below the centre (Picture 5).

The laser alignment system is designed as a help to centre to parts to each other and not for actually measuring a deviation. The display in Millimetres is virtually linear up to a value of approx. +/- 0.50. When deviations are in excess of this value there is a variance in the linearity which can be up to 12% at 1.5mm off the centre. That is to say that the accuracy of the system's linearity increases towards the centre of the sensor.

Technical data

Laser-Alignment System ECO-PSD		Unit
Power supply	2 x Batteries (6LR61), 9V	V _{DC}
Max. current consumption	5	mA
Displays	LCD with digit-size 14	mm
Resolution	10	µm
Measurement rate	3 measurements	1/s
Accuracy up to +/- 0.50 mm	1% of the effective value + 1Digit	-
Accuracy up to +/- 1.00 mm	5% of the effective value + 1Digit	-
Accuracy up to +/- 1.50 mm	12% of the effective value + 1Digit	-
Daylight filter	Cut-off wavelength 600	nm
Sensor connector	2 screened connector Binder type 712 5 poles, screw locked	-
Display connector	1 screened connector Binder type 712 5 poles, screw locked	-
Degree of protection (IP Code)	IP 40	-
Operating temperature	0 ... +40	°C
Storage temperature	0 ... +50	°C
Operating range	0.1 ... 15	m
Sensor cable, screened 5x0.14mm ²	5 **	m
Weight	Display unit	415 (incl. batteries)
	Sensor	190

Unless indicated otherwise these values are correct under normal operation conditions.

** Standard cable length, other length on quest.

Display

Dimensions

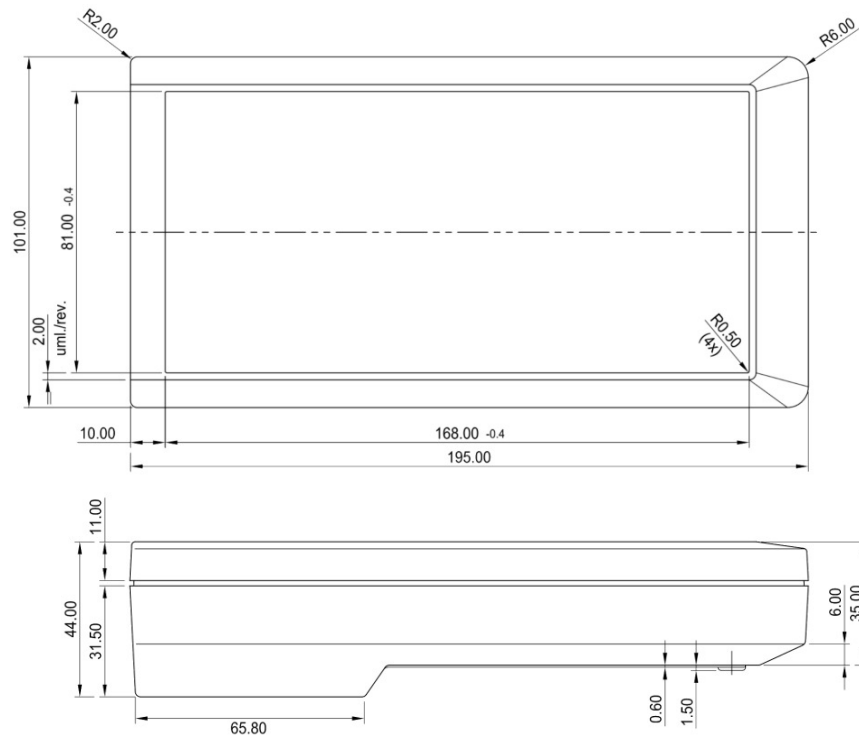

Sensor

Dimensions

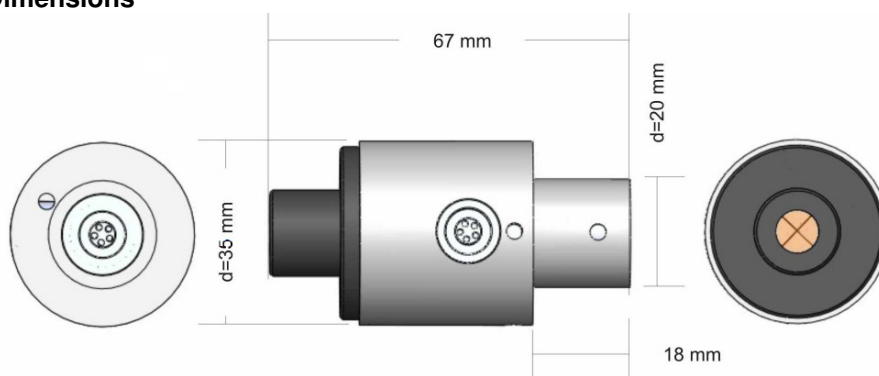

Laser

For best results we recommend the use of a laser with a round beam profile. Laser sources are available in a wide variety of configurations. Possible options are laser modules from the ILEE LDA Series, optical/mechanical centred lasers or laser with an optic/mechanical adjustment such as the ILEE JULA-Laser. For assistance in the selection of a suitable laser for your particular application please ask our application consultants.